

Features

- Magnifying Makeup Mirror
- With Touch Dimmer: Light Color Infinitely Adjustable
- Battery Operated
- On-off Function
- Automatic Off After 10 Minutes
- Magnification 5X
- Double Arm, Extendable
- Polished Chrome Finish
- Made of Acrylic and Solid Brass
- Free of Distortion

WS 85 Touch



SKU# | Option:

- WS 85 Touch | Magnification 5X

Collection
Spiegel

Model |
WS 85 Touch

Dimensions Metric

1 inch = 2.54 cm

1 inch = 25.4 mm

WS®
BATH
COLLECTIONS

1051 Lea Drive - Collegeville, PA 19426
Tel. 215 513 9400 - Fax 610 831 0215

www.ws bathcollections.com - info@ws bathcollectins.com

Product Specs Sheets

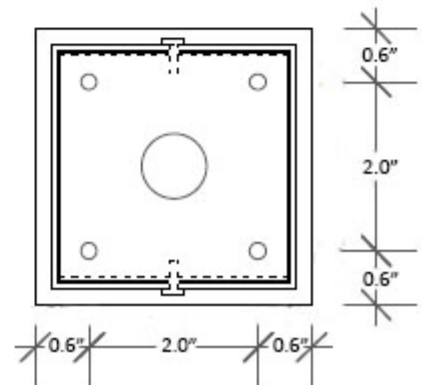
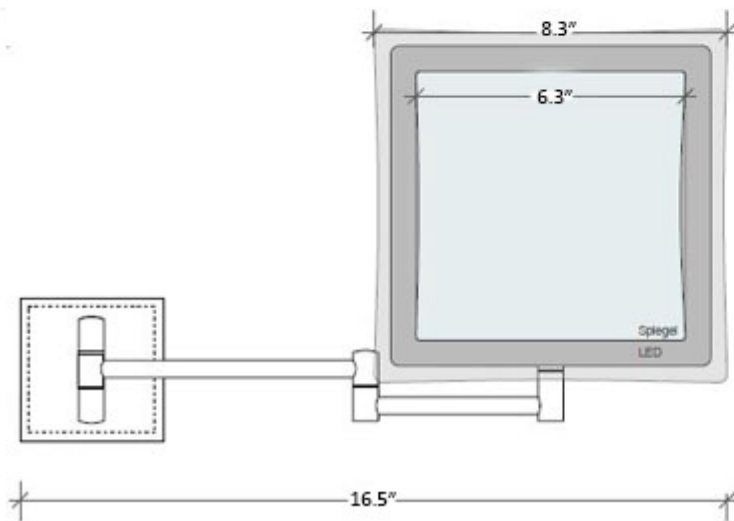
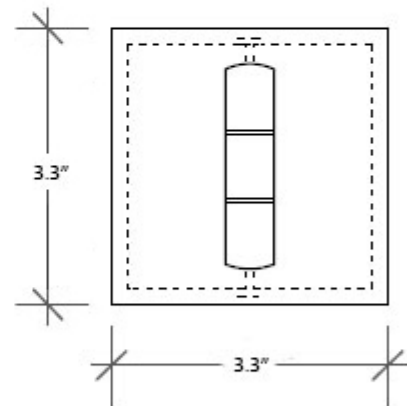
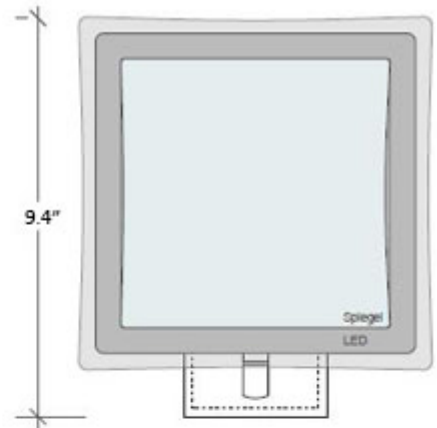
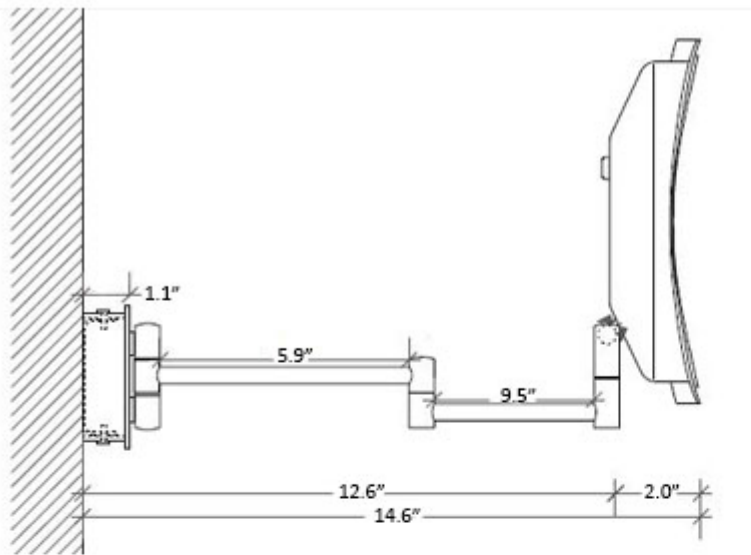

Collection
Spiegel

Model |
WS 85 Touch

Dimensions Metric
1 inch = 2.54 cm
1 inch = 25.4 mm

WS[®]
BATH
COLLECTIONS

1051 Lea Drive - Collegetown, PA 19426
Tel. 215 513 9400 - Fax 610 831 0215
www.ws bathcollections.com - info@ws bathcollections.com

Product Specs Sheets

Type of Mirror	Cosmetic Mirror Wall Mounted Illuminated
Magnification	5 X
Shape	Square
Dimension	9.3" x 8.3" x 14.6"
Dimension of Mirror	6.3" x 6.3"
Switching Function	On/Off Switch. Auto-off after 10 minutes. Direct Connection.
Weight	2.6 LBS
Raw Material	Brass. Satinised Glass
Surface	Chrome
Lamp Details	36 x LED. 2.8W. 15000h
Lamp Color	5000 K
Location	Indoor



Collection
Spiegel

Model |
WS 85 Touch

Dimensions Metric

1 inch = 2.54 cm
1 inch = 25.4 mm

WS[®]
BATH
COLLECTIONS

1051 Lea Drive - Collegeville, PA 19426
Tel. 215 513 9400 - Fax 610 831 0215
www.ws bathcollections.com - info@ws bathcollections.com