

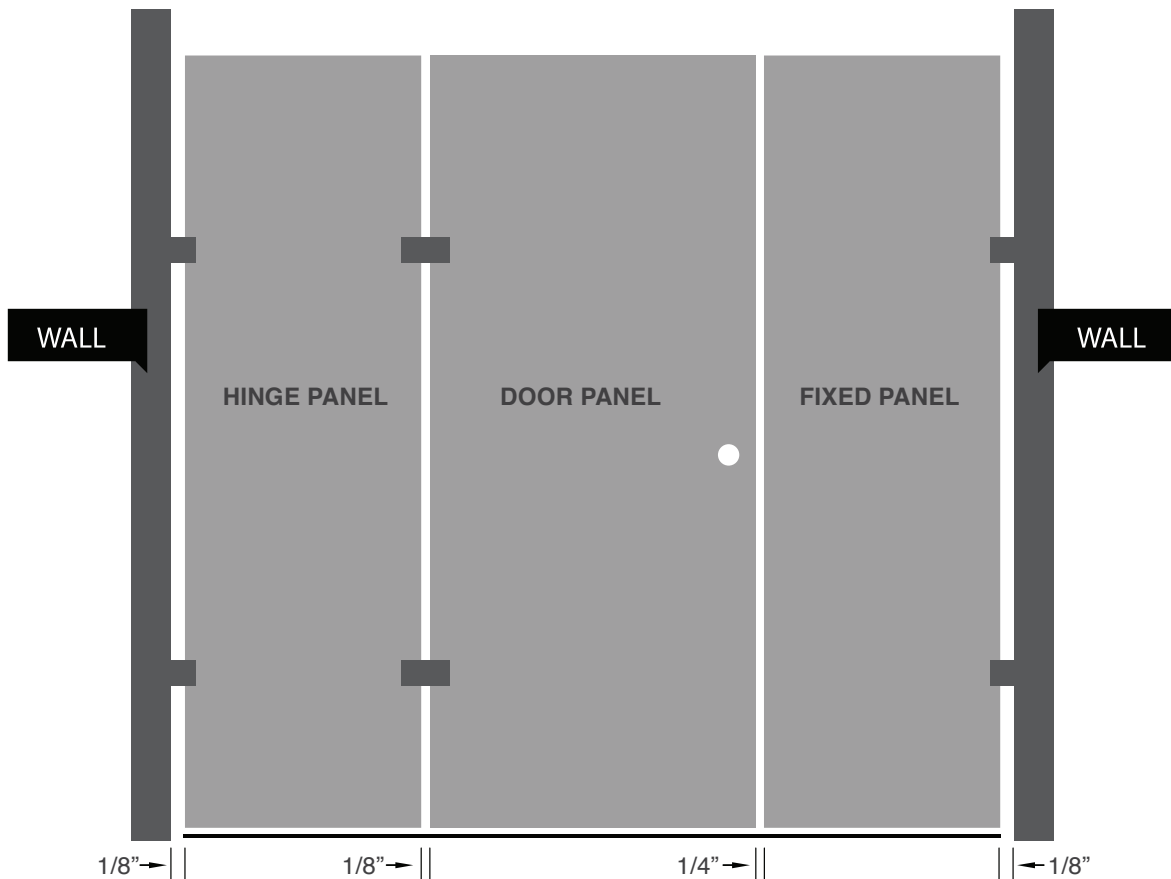

Glass Warehouse

Glass Hinged Fixed 3 Panel Inline Shower Installation Guide



BEFORE YOU START

The most fragile parts of tempered glass panels are the corners. Therefore, it is critical you have the rubber blocks in place so the glass never touches the tile surface you are installing onto. Please make sure the glass is always on blocks while out of the packaging prior/during install. Rubber block is provided in your hardware pack however you can use wood, cardboard or other rubber products to protect against breakage.

Silicon is not provided this will need to be purchased separately. We recommend using clear, mold resistant silicon which can be purchased at your local hardware store.

The items included for this shower enclosure are listed below. This model ships in **5 packages**:

1. Fixed panel
2. Door panel
3. Hinge panel
4. WH Sweep set – (1 full length sweep, 1 bottom sweep)
5. Hardware pack – (2 hinges, 6 mounting clips, 1 door handle, 1 45° shower rod)

PART ONE – Measuring and Marking up layout

IMPORTANT: It is extremely important that the initial lines that you draw are level and straight to insure that all 3 panels will line up perfectly once installed.

1. Determine how far in from front edge of threshold you wish to install the shower enclosure. Using a pencil, mark this distance on both sides of enclosure to ensure that the shower is installed straight. Place a level on the point marked and draw a level vertical line at least 72" up each wall. **It is very important these lines are level.**
2. On the Threshold/Floor, mark a straight line across the entire span- wall to wall. This line should originate from the point where your vertical lines for the fixed and hinge panels meets the threshold/floor.
3. You now have 3 level lines that will guide your shower installation process.

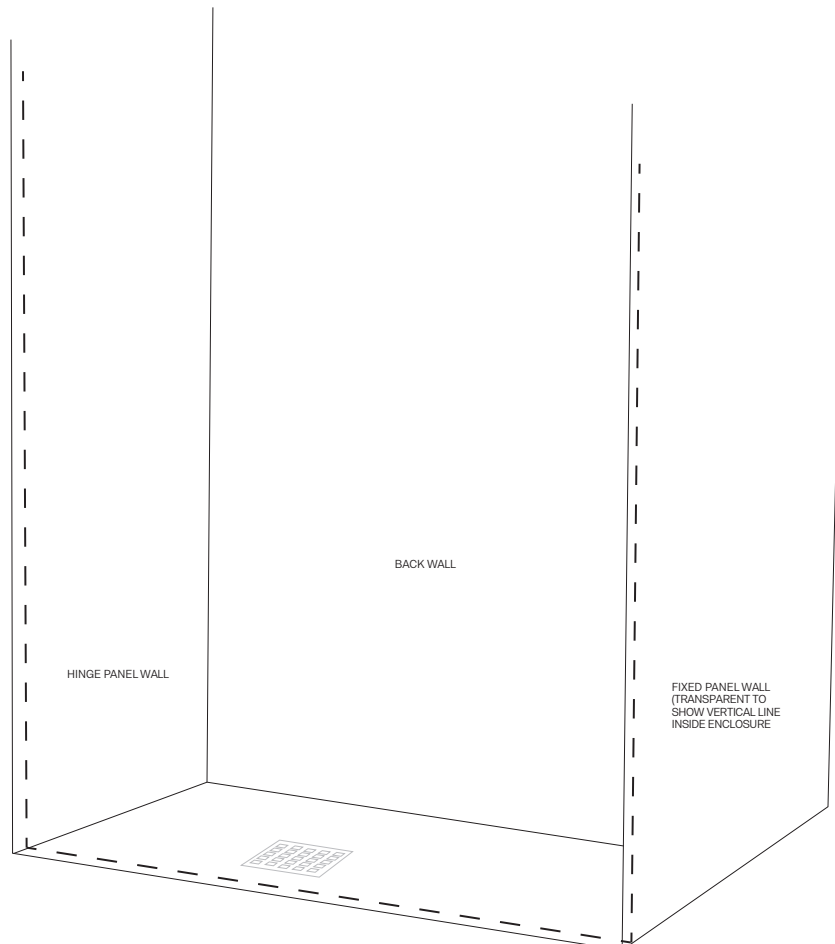

PART TWO – Install mounting clips for Hinge Panel and Fixed Panel

1. On both the Fixed and Hinge Panel walls, mark the center point for the two wall clips.
 - a. Top clip: measure 70 1/4" from the floor up along the vertical line and mark this point.
 - b. Bottom clip: measure 7 3/4" from the floor up along the vertical line and mark this point.
 - c. For the floor clip placement, measure width of the stationary panels and subtract 3 1/2" – measure this distance out from wall and mark along the line that you've drawn on the Threshold/Floor. For example of this, see illustration following page.

NOTE: If installing this glass panel on a fiberglass pan, use a standard 1/8" drill bit instead 1/4" tile drill bit to drill the hole for the clips on the fiberglass pan. You will not use the wall anchor provided just screw the clip directly into the pan. Before screwing the clip down make sure you put a small bit of silicone on the bottom of clip and in the hole to waterproof this hole.

2. Drill clips to the wall / floor.
 - a. Drill holes using a 1/4" tile drill bit and insert the plugs provided.
 - b. Place clip over hole and drill in screws to secure the clip. Make sure these are tightly secured to wall.

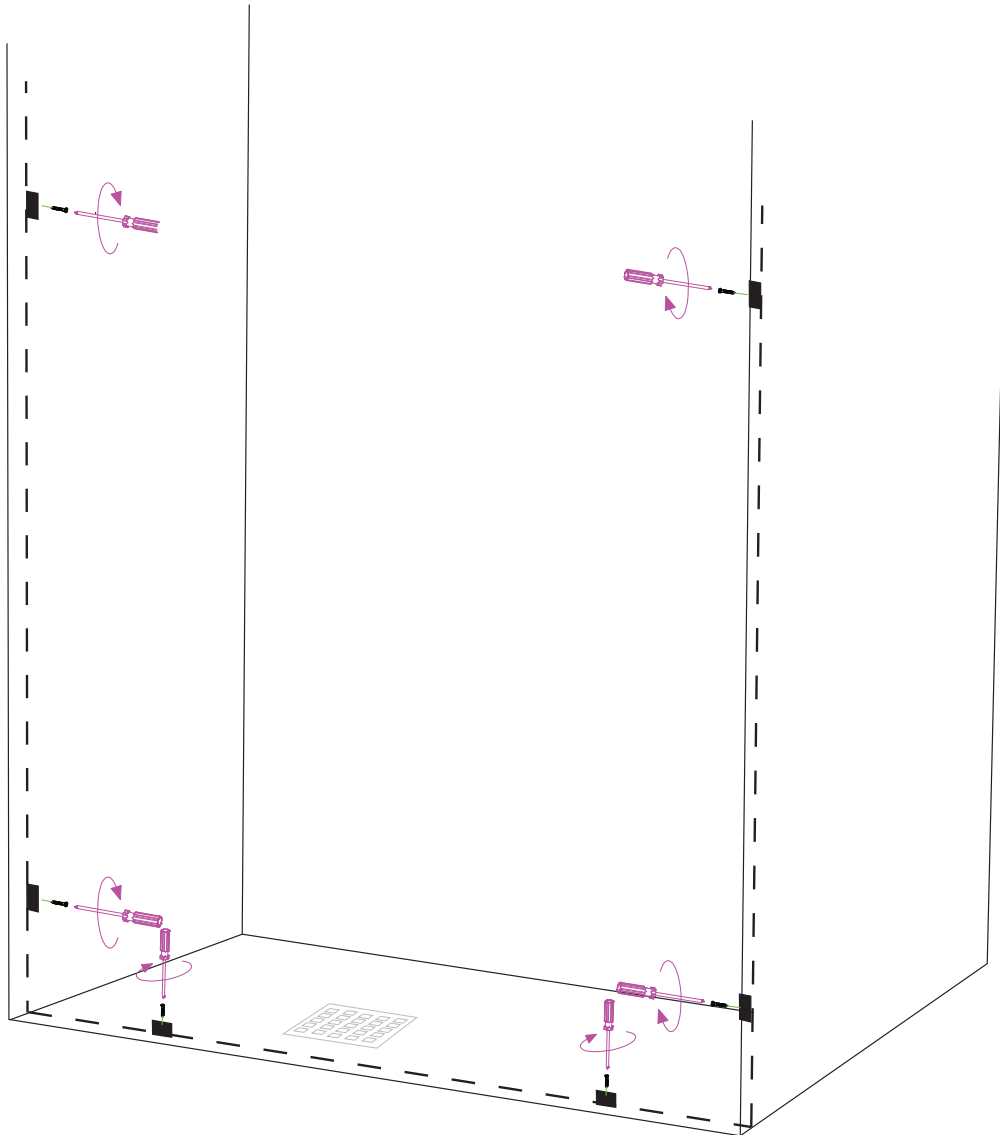

Instructions continued over page

PART THREE – Installing Hinge Panel and Fixed Panel

1. Set the fixed panel in place.
 - a. Place the 1/8" thick rubber block provided on the ground 3 inches from the edge of the panel closest to wall, place the 1/16" rubber block inside the clip on the floor, this is to prevent the glass touching the floor tile or clip where all the weight is. No rubber blocks are required in the clips on the wall. There are extra rubber blocks in case your floor is not level. These rubber blocks are found in the small yellow envelope stapled to your instructions.
 - b. Carefully place the fixed panel on the rubber blocks and in floor clip and slot the glass into the clips on wall.
 - i. **IMPORTANT:** The most fragile parts of the glass panels are the corners. Therefore, it is critical you have the rubber blocks in place so the glass never touches the tile surface you are installing onto.
2. Ensure the fixed panel is level.
 - a. On the glass edge furthest from the wall use a spirit level to make sure the fixed panel is level and in line.
 - i. **TIP:** Use additional rubber blocks on either existing blocks to raise/drop the fixed panel if required.
3. Repeat same process as above for setting the Hinge Panel. For example of this, see illustration following page.

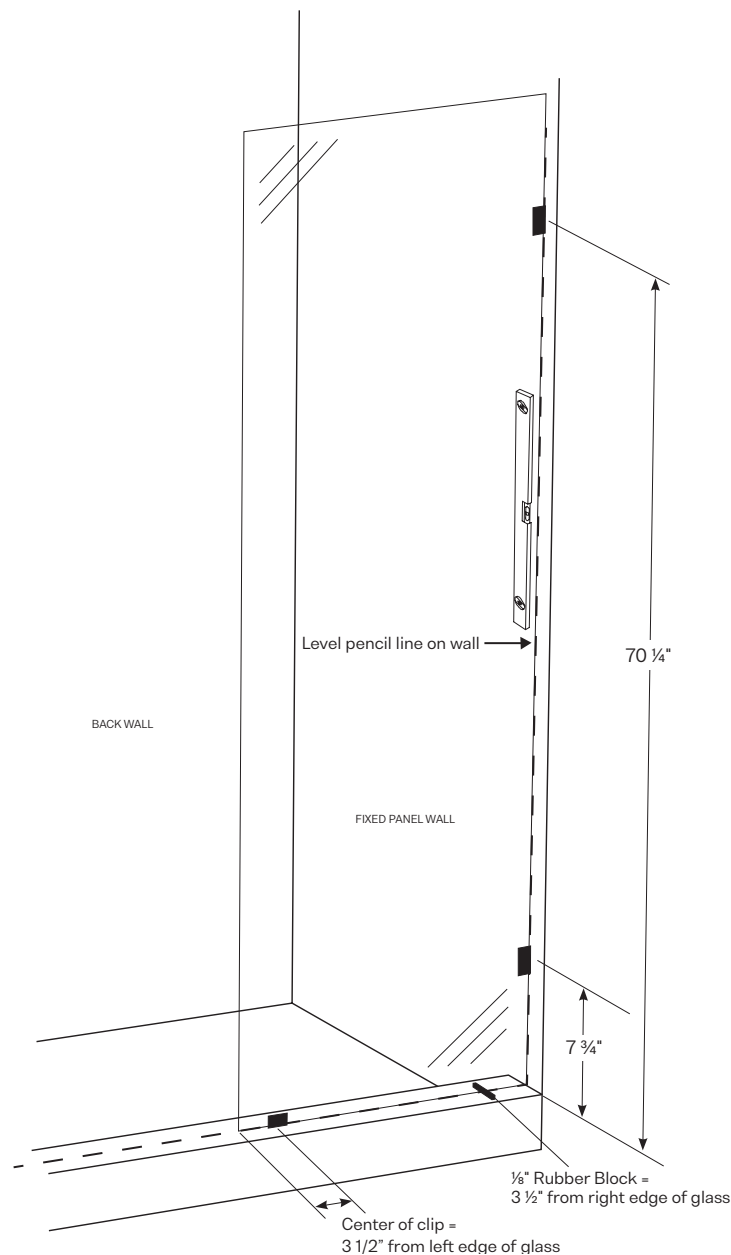

Instructions continued over page

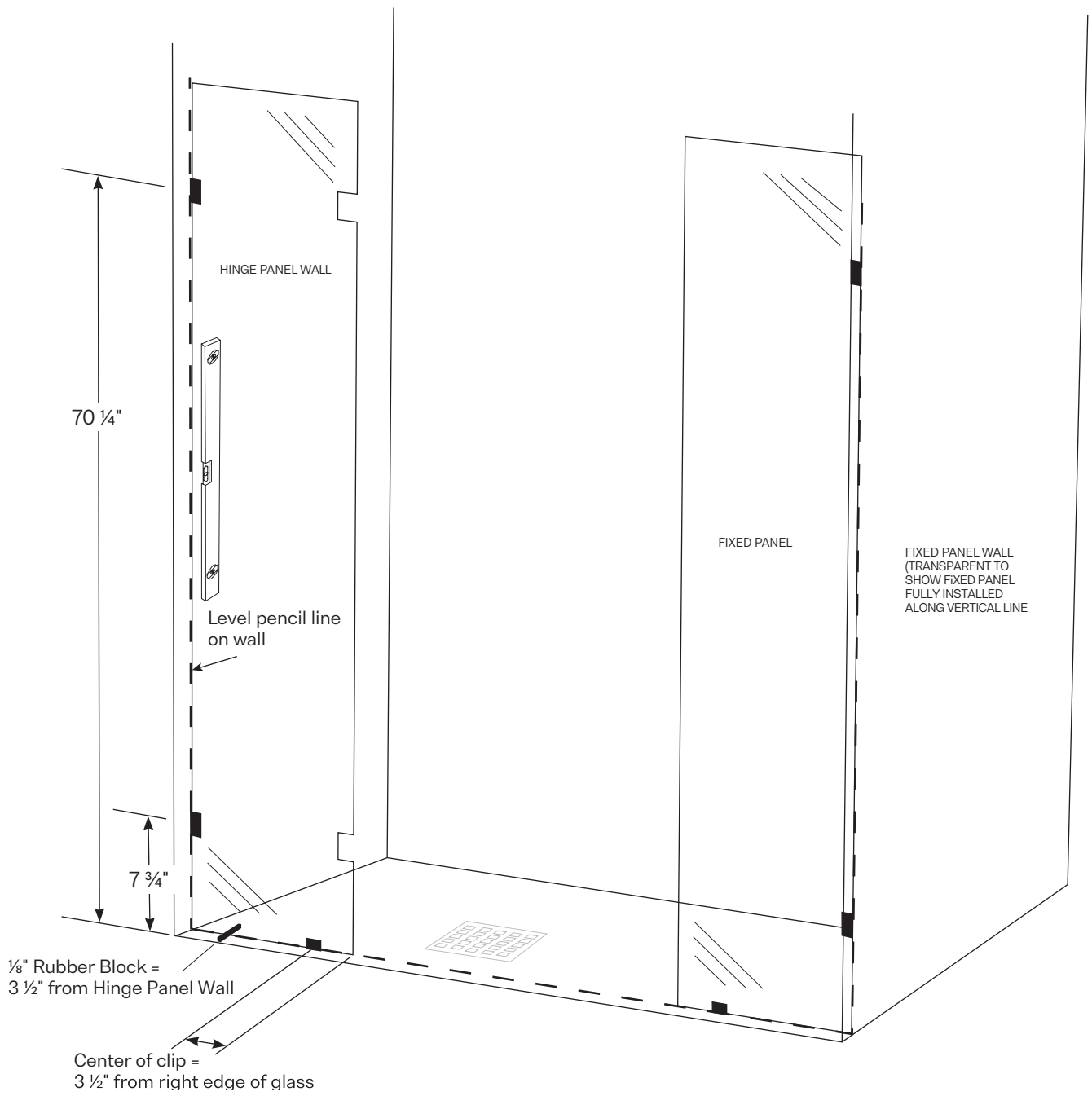

Instructions continued over page

PART FOUR – Check Measurements and Level – Hinge & Fixed Panels

1. Using a level, check that the Hinge Panel and Fixed Panel line up across the top and are perfectly level.
 - a. If panels are not level, using rubber block provided, place under the panel sitting lower and adjust to raise so that the panels meet and are level at the top.

IMPORTANT: Aligning the Hinged and Fixed panels and making sure that they are level is extremely important prior to siliconing the panels.

2. Carefully measure the (Door) opening from edge of Hinge Panel to the edge of the Fixed Panel. Measure this opening at the top, middle and bottom of your Door opening. This opening measurement should be at least the width of your door panel plus 1/4" for the door to properly fit in this space. **If the opening is smaller than the door panel width + 1/4" please contact Glass Warehouse on (760) 536 3640 so we can solve this issue for you.**

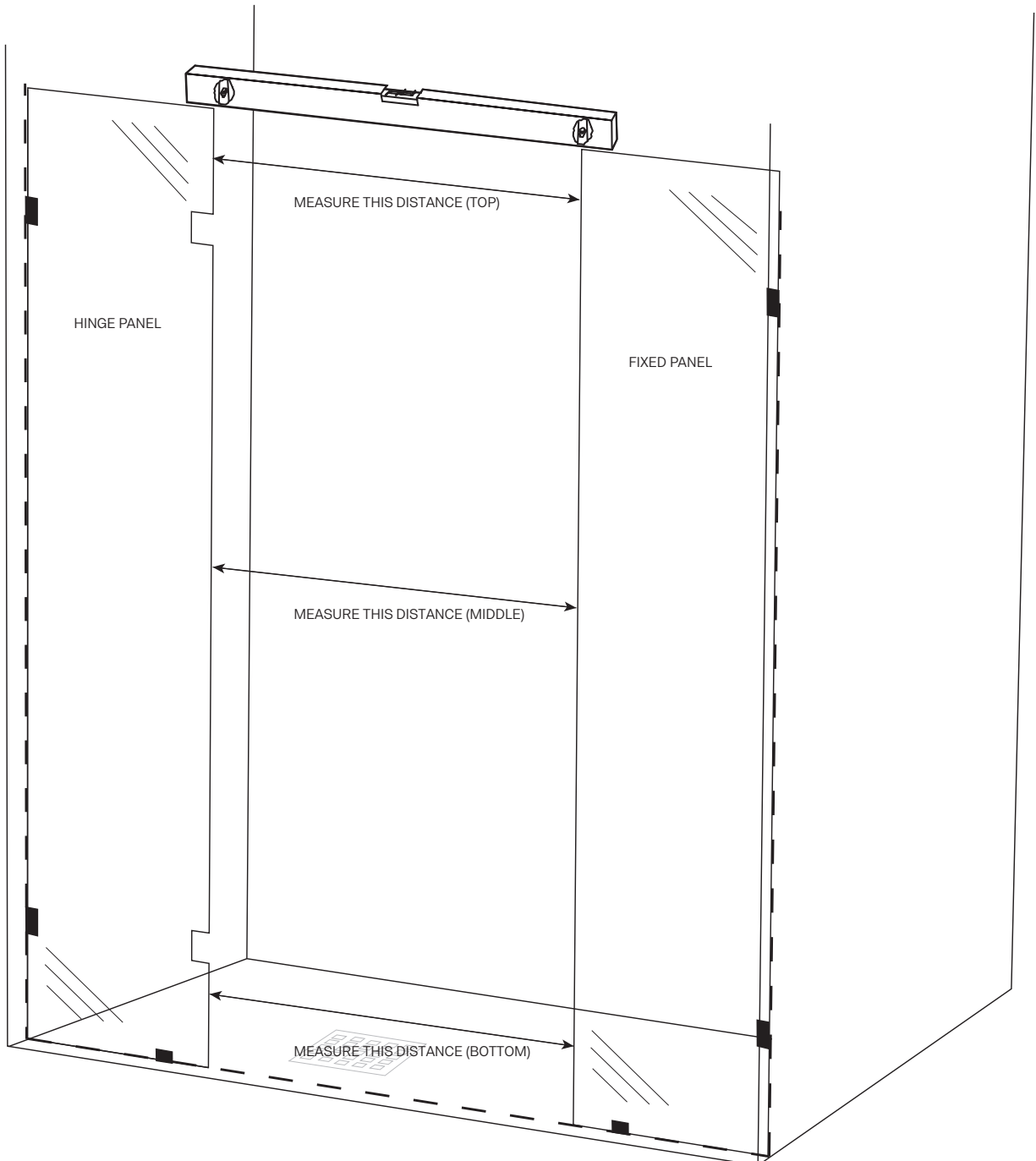

3. Once all panels are leveled and measurements have been checked, install the 45 degree shower rod on the inside wall of hinge panel.
 - a. Loosen the end of bracket on rod that fits over the top of glass panel and slide to fit on top edge of panel.
 - b. Position the rod back to wall so that 45 degree corner sits flush on wall and make sure the rod is level in height. Mark the wall with pencil where bracket hole meets the wall and once marked, remove the rod.
 - c. Using a 1/4 inch tile drill bit, drill the hole in wall and insert the wall plug provided.
 - d. Re-install the 45 degree shower rod on glass and screw the other end to the wall. Once screwed into wall, tighten the grub screw on other end where bracket is attached to glass panel.

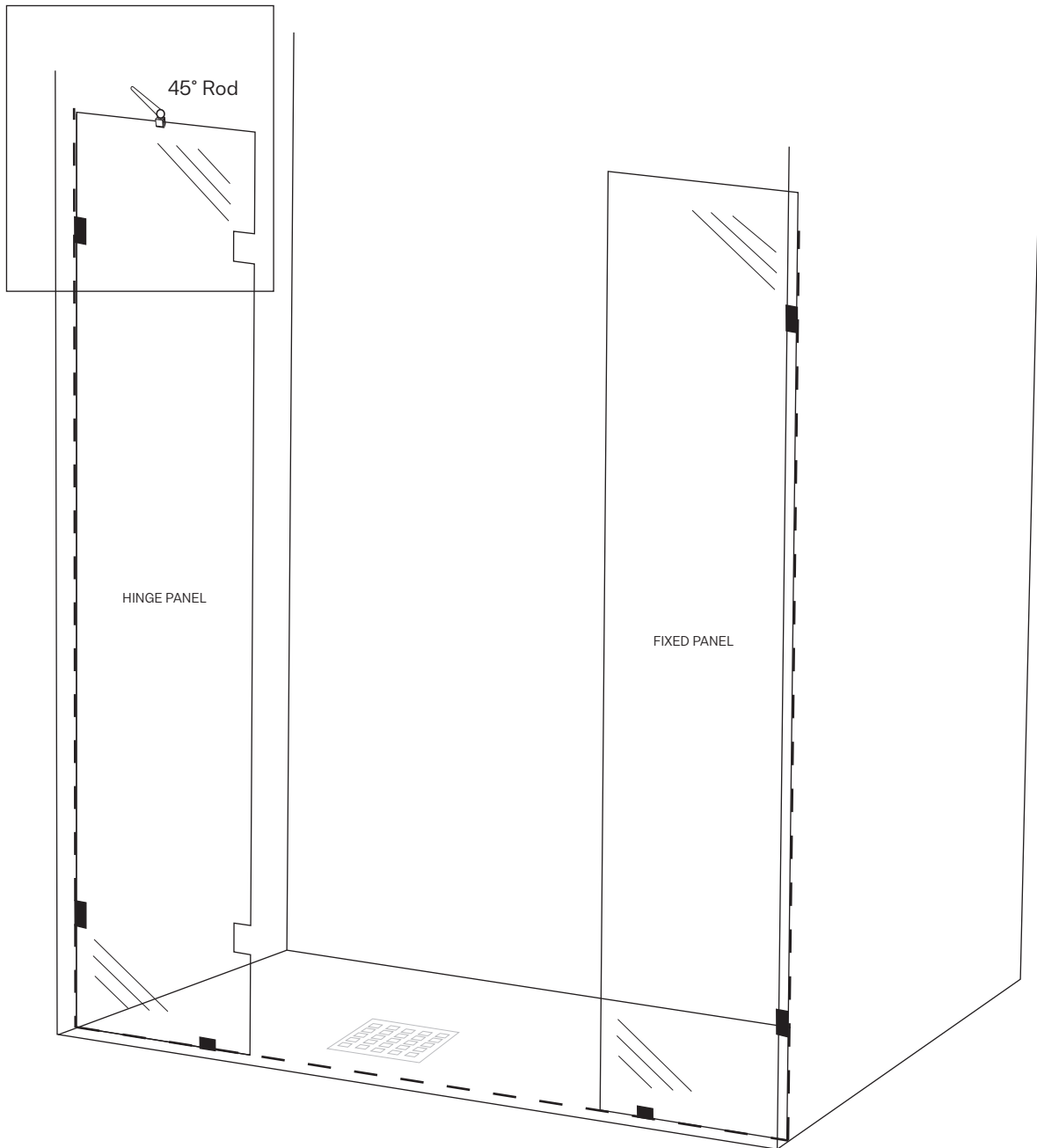

PART FIVE– Silicone Hinge and Fixed Panel

IMPORTANT: Siliconing your panels is essential as not only does this prevent your panel from leaking water it is also imperative to the integrity and strength of the shower enclosure.

1. If the size / opening for the door is okay (matches the width of the door panel + 1/4") silicone the wall and floor surface of the Hinge and Fixed Panels. You need to silicone the inside and outside of the shower, and be sure to fill the space between the wall/floor and the glass panels with silicone. Siliconing the Hinge and Fixed Panels is imperative for the structural integrity of this shower model. The heavy door panel may pull this out of place if the Hinge and Fixed Panels are not securely siliconed in place.
 - i. **TIP:** Spraying the silicone with water after applying the silicone and using a spatula of some kind to remove the silicone residue will give you a nice clean and professional finish.
2. **Once you have completed siliconing the Hinge Panel and Fixed Panel into place, it is critical you leave the silicone to set for 36 hours. Whilst the silicone is setting please leave the door panel off and only hang the door once silicone has cured.**



PART SIX – Install Door Panel and Sweeps

1. Attach the hinges to the hinge panel.
 - a. Ensure you have the hinges placed in the correct direction. The side of the hinge with the solid plate is attached to the hinge panel. The side with the screws of the hinges should be on the inside of the shower enclosure.
 - b. Lightly tighten each screw with the allen keys provided so the hinges are lightly secured only.
 - i. **TIP:** Center each hinge to the cutout allowing some space to adjust the height of the door panel once installed.

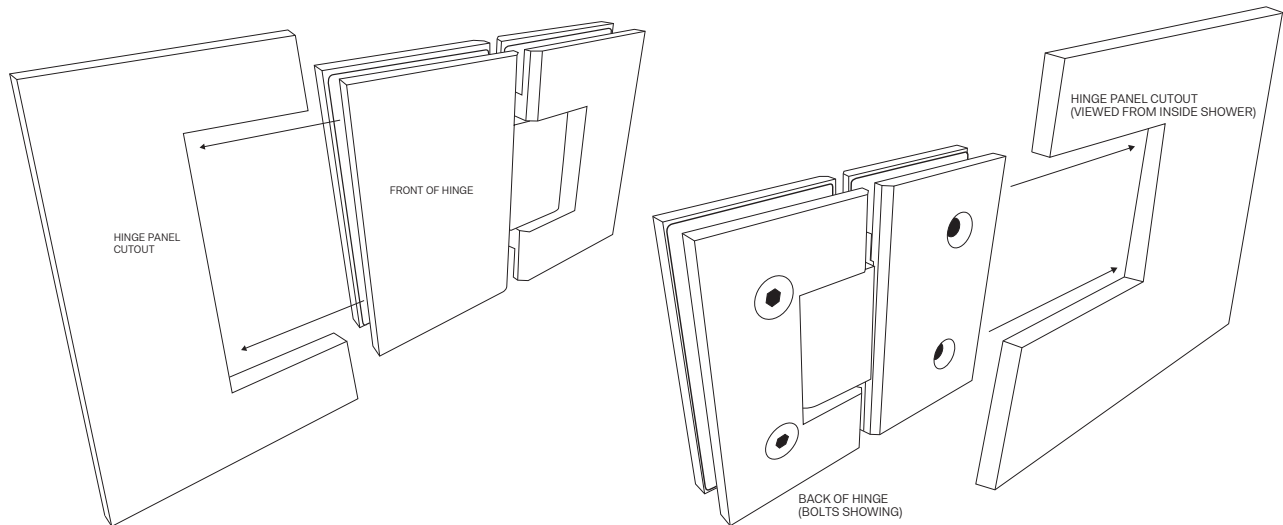

2. Attach the door handle to the door panel.
 - i. **IMPORTANT:** Ensure the handle is firmly attached.
 - ii. **TIP:** Most DIY-ers won't have professional suction/vacuum equipment to lift the glass, so this is why we recommend attaching the door handle first so when lifting the glass you have something secure to hold onto.

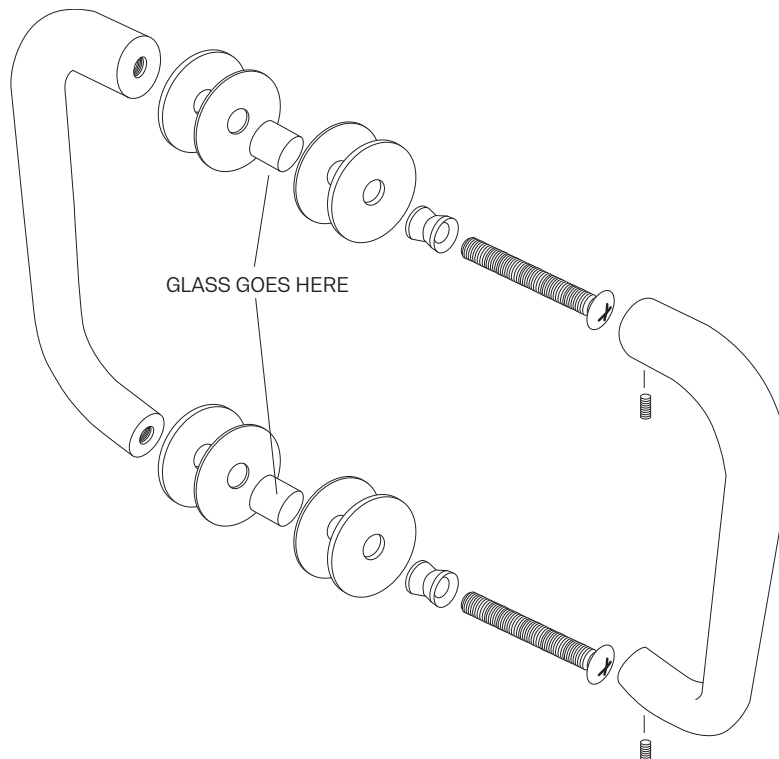

3. Take off the backing plates of the hinges on the door side.

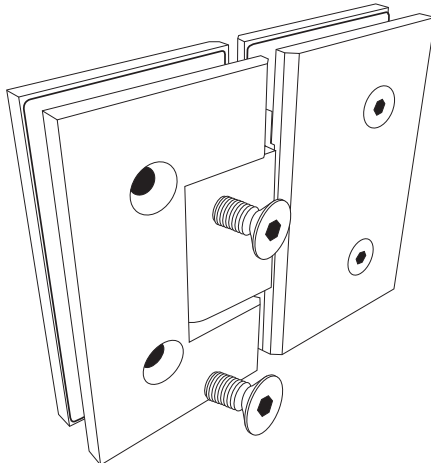

4. Set the door panel in place.
- Place the 3/8" thick rubber blocks provided on the ground 2-3 inches from each edge of the Door Panel
 - Carefully place the Door Panel on the blocks and make sure the top of the hinge panel, door panel and fixed panels line up and are level. If you need to adjust the height of the door panel in order to be level at the top you can simply use the smaller rubber blocks provided. Door must be placed on rubber blocks at all times. **DO NOT PLACE DOOR PANEL DIRECTLY ON TILE.**
 - The gap between the Hinge Panel and Door Panel should be 1/16" to 1/8". The gap between the Door Panel and Fixed Panel should be 1/4" so as to install the sweep.
 - NOTE: The door panel is 1/4 inch shorter than the hinge and fixed panels so as to allow for the door to swing open and closed and to fit the bottom sweep for door panel to prevent water leakage.
 - Put the backing plates on hinges and tighten all 4 screws on each hinge, now make sure these screws are very tight so that your door panel won't drop once the rubber blocks are taken away.
 - Take the rubber blocks out from under the door and lightly swing door to make sure it is not binding anywhere.

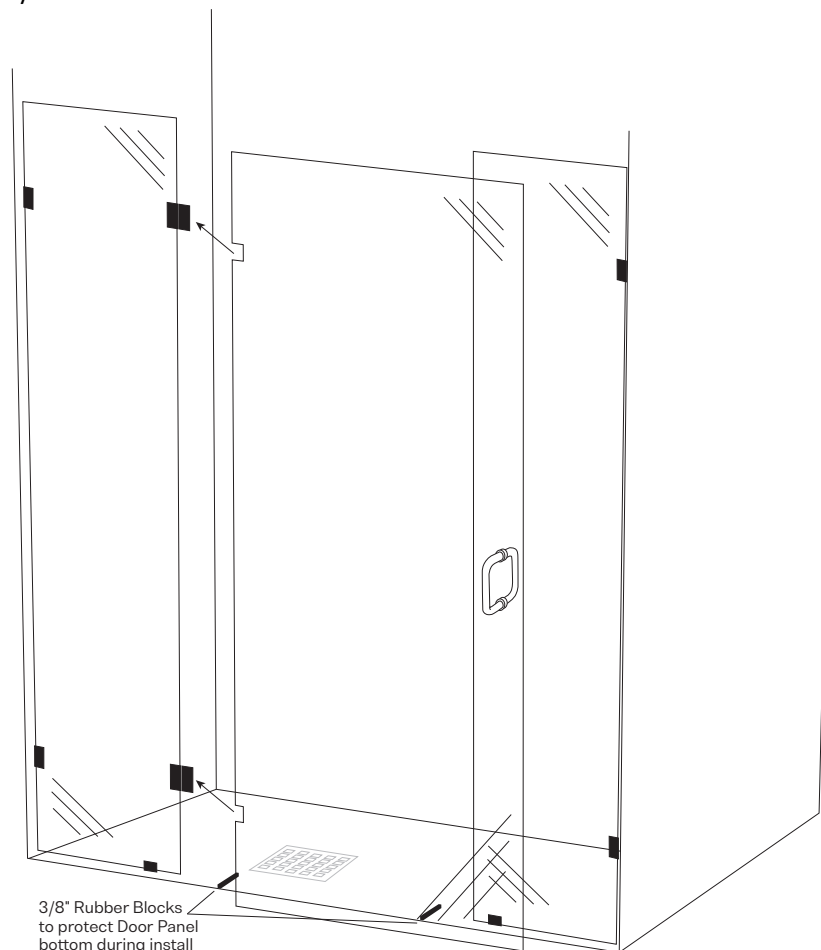

3/8" Rubber Blocks
to protect Door Panel
bottom during install

5. Once you are confident with the positioning of the door and the hinges are very tight, locate the 78" sweep that will seal the space between the Door Panel and the Fixed Panel. Attach the sweep on the edge of the Fixed Panel that meets the Door Panel (see Figure A below).
Locate the 30" door sweep (see Figure B below). Measure the width of your door and trim the sweep to match your door size. Slide sweep on to the bottom of door panel to prevent any water leakage from under the door. Please make sure the bottom of the door is very clean before installing.

FIGURE A

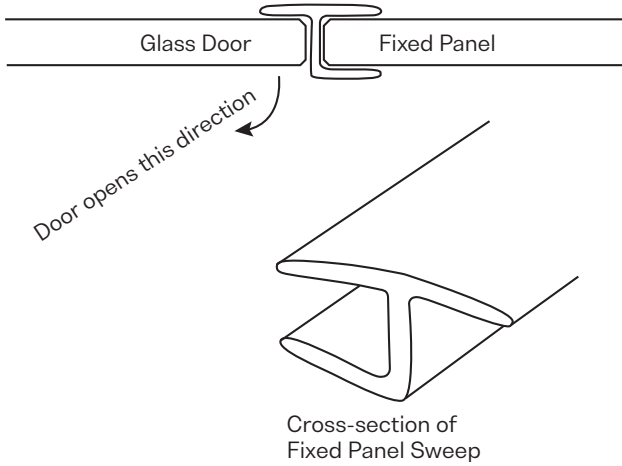
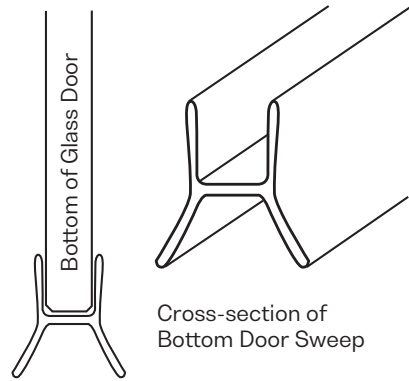

FIGURE B



Glass Warehouse is here to assist you, so if you run into any troubles or have any queries don't hesitate to contact us on: inquiries@glasswarehouse.us or (760) 536-3640



Care & Maintenance



Glass Warehouse

EnduroShield makes your cleaning easier and less frequent; however it is recommended that you continue to clean the surfaces regularly.

Maintaining the Treated Surface

For best results simply drying the glass with a squeegee or towel after each use will help keep the glass clean and reduce mineral spots forming. The glass needs to be cleaned every few weeks using a damp microfiber cloth and a mild detergent to break down soaps, oils, and conditioners on the glass. General glass cleaners are also suitable, however most of these are finishing agents rather than cleaners, and are an added expense that is not required.

Hard Water Maintenance

In hard water areas, or areas where water drops dry and leave a noticeable dust mark, a build of minerals may occur on the protective treatment. While these may not be removed as easily with the mild detergent, mild acids will often remove the marks quickly. As needed white vinegar should be used to wipe down the glass. Keep in mind the vinegar may be diluted with water, however dilution reduces the effectiveness.

Spray vinegar onto the glass and allow to soak for several minutes. This should dissolve any mineral deposits that have built up on the glass surface. A damp microfiber cloth should then be used to wipe over the surface. For extreme hard water areas we recommend using undiluted vinegar every week or so as a cleaning option to reduce this build up on the surface, rather than allowing the build up to continue over a long period of time.

Caution: Prohibited Products **Note these may damage the treatment and void any warranty*

- > Avoid the use of any abrasives or polishes including water spot removers, toothpaste, polishes, rough, or gritty substances
- > Avoid the use of acids or alkalis that you would not want in contact with your skin for an extended period of time
- > Avoid products such as Comet, Ajax, Jiff or Cerium Oxide which polish back the actual substrate
- > Avoid the use of any harsh or chemical cleaners, with correct maintenance these are never required

Approved Cleaning Products

The below products have been tested for compatibility with EnduroShield, however there are no specific products that must be used. We feel you should not be required to purchase extra products in order to keep your glass clean. With correct maintenance, all you need for clean glass beyond 10 years is a squeegee, a mild liquid dish soap, and white vinegar.

Any product that does not fall into the prohibited categories listed above will be fine, and below is a short list of acceptable products:

- > Windex
- > SprayWay (or other alcohol based foaming cleaners)
- > Scrubbing Bubbles (or other automatic leave-to-dry daily shower cleaners)
- > 7th Generation, Dawn (or other mild eco friendly cleaners)
- > CLR (Calcium Lime Rust)
- > Mr. Clean Magic Eraser (when damp)

It should be noted that with any cleaner used on the EnduroShield surface a thorough rinse with clean water should follow immediately. Although these cleaners can be used, EnduroShield is designed to be an 'easy clean coating' that does not require harsh or toxic cleaning chemicals to maintain the surface effectively.

If for any reason the recommended maintenance has not been followed for some time, just as it took time for the build up to occur, it will take time to remove the debris from the protected glass surface. This can most commonly be achieved using undiluted white vinegar dampened on a Magic Eraser, or CLR on a Magic Eraser. Depending on the severity of the build up this may take multiple attempts, but once the glass is clean again it will perform like new. Should you have any queries regarding the cleaning of your treated surfaces please contact EnduroShield.

tel: 805 617 4609

email: salesusa@enduroshield.com

www.enduroshield.com

GLASS WAREHOUSE®

Exclusive Limited Warranty

Warranty, Terms and Conditions

This warranty is effective as of JANUARY 1, 2019 on all Glass Warehouse product purchases

PLEASE READ GLASS WAREHOUSE WARRANTY TERMS AND CONDITIONS BEFORE INSTALLING YOUR GLASS WAREHOUSE PRODUCT. BY USING THE PRODUCT, YOU ARE CONSENTING TO BE BOUND BY THE FOLLOWING WARRANTY TERMS AND CONDITIONS

Glass Warehouse offers the following warranty for its products and components thereof. This warranty extends only to the original owner/end-user for household use only and is not transferable to a subsequent owner. Glass Warehouse reserves the right to modify this warranty at any time, it being understood that such modifications will not alter the warranty conditions applicable at the time of sale of the products in question. This warranty extends for a designated period of time, so long as the product remains in use in its original place of installation and that the product must be maintained as described in the owner's manual supplied with the product. This warranty applies only to Glass Warehouse® products purchased from an authorized dealer in the United States or Canada.

Proof of purchase (original sales receipt) from the original consumer purchase must be provided with all warranty claims. No responsibility is assumed by Glass Warehouse for any special, incidental or consequential damages. **IN NO EVENT SHALL THE LIABILITY OF GLASS WAREHOUSE EXCEED THE PURCHASE PRICE OF THE UNIT.**

Glass Warehouse products must be installed by a fully insured, licensed professional and according to the Glass Warehouse installation instructions and guidelines. Installation of Glass Warehouse product by anyone other than a fully insured licensed professional shall **VOID THE WARRANTY**. Glass Warehouse recommends that such licensed professionals have experience in the installation of bathroom products -specifically glass shower and glass tub doors. Installation of certain products, including, without limitation, glass products (i.e., shower and tub doors) by an unlicensed or inexperienced installer may result in glass breakage and, consequently, may cause personal injury or even death and Glass Warehouse will not be liable.

PARTS ONLY WARRANTY – Limited Warranty 3 years

This warranty is extensive in that it covers replacement of all defects. Glass Warehouse may, at its option, examine and inspect the alleged defective product and Glass Warehouse may request that parts be returned to Glass Warehouse at Owner's expense for factory assessment and inspection. If Glass Warehouse determines product to be covered by the above Warranty, replacement parts will be shipped via ground shipping. Increased costs for expedited delivery, if requested by the Customer, will be the responsibility of Customer. Parts replaced under the terms of this Warranty will be warranted for the remainder of the original warranty period. **LABOR CHARGES AND/OR DAMAGE INCURRED DURING INSTALLATION, REPAIR, OR REPLACEMENT, AS WELL AS ANY OTHER KIND OF ANCILLARY COST, LOSS OR DAMAGE ARE EXCLUDED.** Please allow up to 1-3 business days for processing of warranty issued parts. Once warranty replacement parts are shipped, warranty is activated and product cannot be returned for refund thereafter.

SHOWER & TUB DOORS, SHOWER ENCLOSURES GLASS

Glass Warehouse shower doors, tub doors, and shower enclosures are backed by a Limited Lifetime Warranty. Glass Warehouse warrants the glass of shower doors, tub doors and shower enclosures to be free from defects in workmanship and materials under normal residential use for a period commencing from the initial date of purchase by the owner/ end-user, contractor or builder from an authorized Glass Warehouse dealer for the life of the product as long as the original consumer purchaser owns the home in which the product is installed. Warranty for plastic seal strips, sweeps or any other vinyl components shall be limited to one (1) year. Glass Warehouse does not warrant glass for scratches, chips, water spots, breaking or any other damage after installation.

SHOWER & TUB DOORS, SHOWER ENCLOSURE HARDWARE

Glass Warehouse shower door, tub door, and shower enclosure hardware is backed by a Limited Lifetime Warranty. Glass Warehouse warrants shower door, tub door and shower enclosure hardware (i.e. handles, bath knobs, hinges, clips, brackets, shower rods, 90° corner brackets) **in chrome, brushed nickel, satin brass and polished brass finishes only** to be free from defects in workmanship and materials under normal residential use for a period commencing from the initial date of purchase by the owner/ end-user, contractor or builder from an authorized Glass Warehouse dealer for the life of the product as long as the original consumer purchaser owns the home in which the product is installed. Warranty for any part in **oil rubbed bronze or matte black finish** shall be limited to one (1) year.

Glass Warehouse hereby disclaims all warranties for products sold as dealer or store displays. Glass Warehouse hereby disclaims all warranties for products used outside of the United States or Canada whether expressed or implied, including but not limited to the implied warranties of merchantability and fitness for a particular purpose.

WARRANTY TERMS

Glass Warehouse will, at its election, repair or replace the product found by Glass Warehouse in its sole judgment, to be defective within the warranty period under normal residential use and maintenance. The replacement of a product is limited to supplying a replacement product or part (same as existing or if not available, comparable product). Glass Warehouse warranty obligation shall be discharged upon tender of parts, replacement or repair of the product. Purchaser's refusal to accept the tender terminates all warranty obligations and **VOIDS THE WARRANTY**. Cost of freight for returning products to Glass Warehouse for repairs or replacement under this limited warranty are the responsibility of the customer. Cost of freight associated with shipping of replacement product(s) or parts covered by this warranty is the responsibility of the original user. Any product replaced or repaired during the warranty period will be covered only for the remaining period of the original warranty. In no event will Glass Warehouse be liable for costs of repair or replacement of any installation material, including but not limited to tile, marble, etc. **GLASS WAREHOUSE IS NOT RESPONSIBLE FOR INSTALLATION, REMOVAL OR REINSTALLATION COSTS OF ANY PRODUCT REQUIRING WARRANTY SERVICES.**

Any modification or alteration of any Glass Warehouse products will void the warranty. Neither the authorized Glass Warehouse dealer, nor any other person is permitted to make any affirmation, representation, or warranty other than those contained in this warranty. Any affirmation, representation, or warranty other than those contained in this warranty shall not be enforceable against Glass Warehouse or any other person.

Glass Warehouse product installations must be performed by either a Glass Warehouse authorized agent or a licensed, insured and experienced professional contractor - installations performed by any other party shall void the warranty. This warranty shall not apply to breakage or damages caused by normal wear and tear, fault, carelessness, abuse, misuse, misapplication, improper maintenance, alteration or modification of the unit, as well as chemical or natural corrosion, accident, fire, flood or any other casualty. Improper care and cleaning will void the warranty. Use of cleaners containing abrasive cleansers, ammonia, bleach, acids, waxes, alcohol, solvents or other products not recommended for hardware finishes, glass or acrylic as they may damage the metal or glass finish of your shower door or shower enclosure and will void the warranty. For additional product maintenance instructions please refer to the product installation manual. Glass Warehouse is not responsible for any issues arising in connection with errors or omissions in information provided on Glass Warehouse or dealers' websites. This warranty does not extend to any non-Glass Warehouse plumbing or components installed by installers, end users or by any party other than Glass War.

THE FOREGOING WARRANTIES ARE IN LIEU OF ALL OTHER WARRANTIES, EXPRESSED OR IMPLIED, INCLUDING BUT NOT LIMITED TO THE IMPLIED WARRANTIES OF MERCHANTABILITY AND FITNESS FOR A PARTICULAR PURPOSE. BATH AUTHORITY LLC ("GLASS WAREHOUSE") AND/OR SELLER DISCLAIMS ALL LIABILITY FOR SPECIAL, INCIDENTAL OR CONSEQUENTIAL DAMAGES. GLASS WAREHOUSE IS NOT LIABLE FOR PERSONAL INJURIES OR DEATH TO ANY PERSON OR FOR ANY DIRECT, SPECIAL, INCIDENTAL OR CONSEQUENTIAL DAMAGE, LOSS OF USE, LOSS OF TIME, LOSS OF PROFITS, INCONVENIENCE, INCIDENTAL EXPENSES, LABOR OR MATERIAL CHARGES, OR ANY OTHER COSTS RESULTING FROM THE USE OF ITS PRODUCTS OR PERTAINING TO THE APPLICATION OF THE PRESENT WARRANTY, OR RESULTING FROM THE REMOVAL OR REPLACEMENT OF ANY PRODUCT OR ELEMENT OR PART COVERED BY THIS WARRANTY.

COMMERCIAL USE AND OTHER EXCLUSIONS

This warranty excludes all industrial, commercial and business usage. The warranty period for products installed for commercial applications or used in commercial ventures, including but not limited to motels, hotels, casinos, student housing, condos, apartments, and fitness centers, is a one (1) year limited warranty from the date of purchase for shower doors, bathtub doors, shower enclosures and a three (3) month limited warranty from the date of purchase for mirrors, with all other terms of this warranty applying except the duration of the warranty.

WARRANTY SERVICE

To file a warranty claim the following information is required:

- Name, address and telephone number
- Product model number
- Brief description of problem (please note that additional information such as photos may be required to fully process your warranty claim)
- Proof of purchase (sales receipt, invoice, etc.)
- PO, Invoice or original purchaser name

Submit required information by e-mail: accounts@glasswarehouse.us

Or, contact Technical Support Monday – Friday 8am – 5pm – PST

Technical Support: 760-536-3640