

W Walker
E Edison
furniture company

Item #: BTW 40
Assembly Instructions

OPTION 1

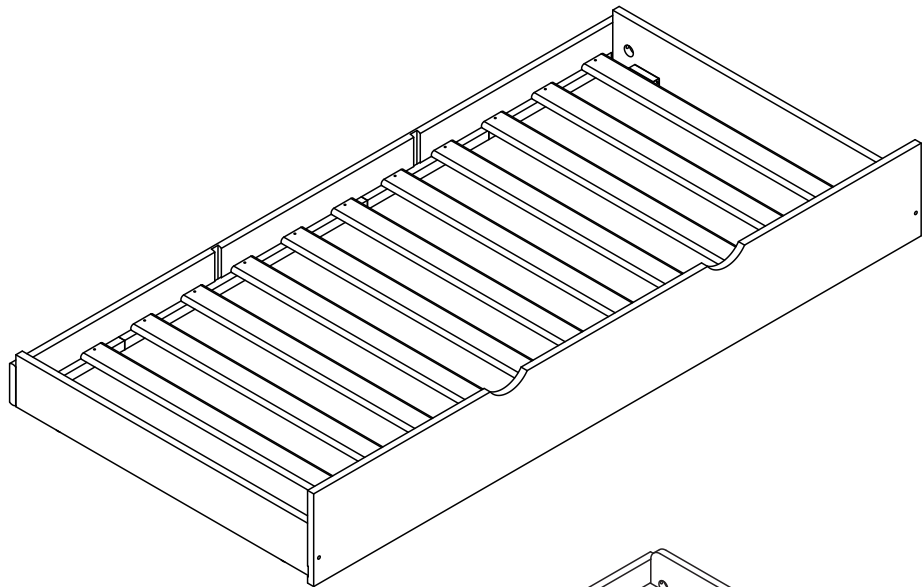

OPTION 2

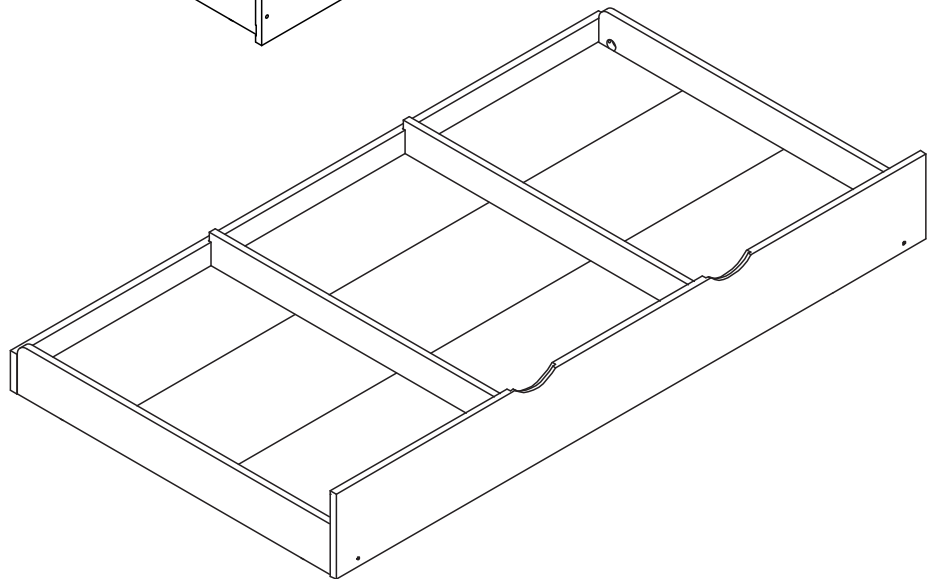

For the most current instructions, additional assembly tips, to report damage or request parts, please visit our website at www.walkerredison.com.

Revised 06/2017



Instruction Manual

***IMPORTANT INFORMATION
READ BEFORE ASSEMBLING THIS PRODUCT***

Follow the information on the warning labels found on the bed and on the packaging.
Do not remove the warning label from the bed.

Use only a mattress with the dimensions 74-75 in. L x 37.5-38.5 in. W x 6 in. H is recommended.

The use of a water or sleep flotation mattress is prohibited.

Replacement parts, may be obtained from any of Walker Edison Furniture Company's dealers or by contacting us online at www.walkerredison.com.

DO NOT use substitute parts. Contact the manufacturer or dealer for replacement parts.



Periodically check that the components of the bed are in their proper position, free from damage, and that all connectors are tight.

Keep these instructions for future reference.

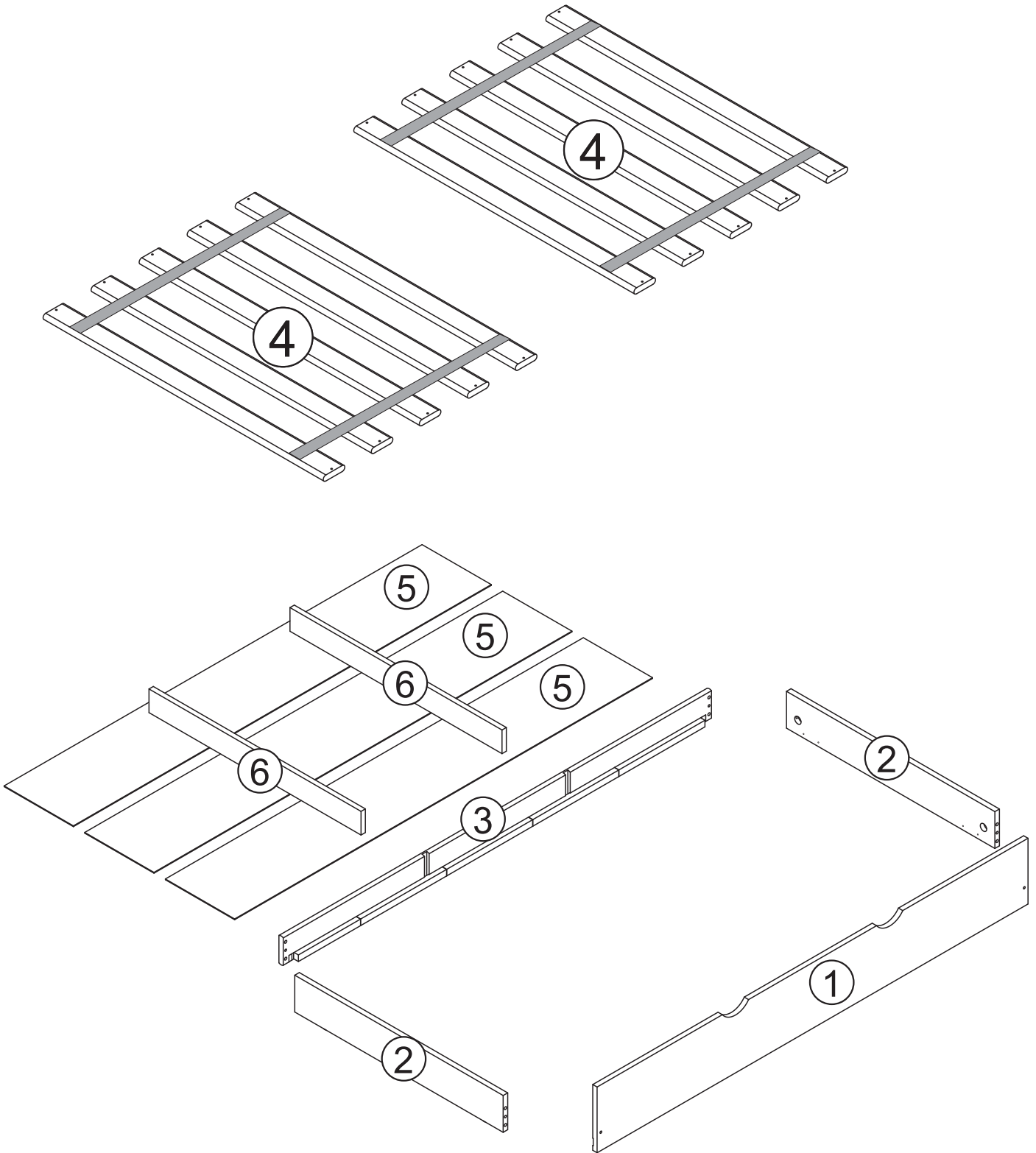
Parts List

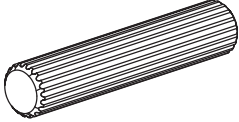
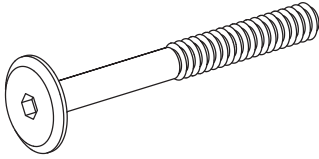

Hardware List

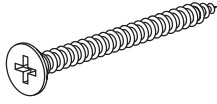
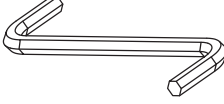
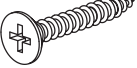
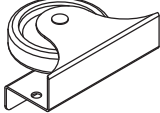
Ref.		Qty.
A	 10x40mm	08
B	 1/4"x70mm	04
C	 1/4"	04
D	 4,0x30mm	20
E	 Hex Key	01
F	 3,5x16mm	16
G	 Wheel	04

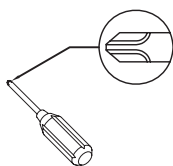
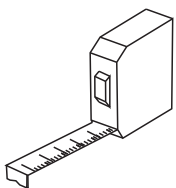

Philips head screwdriver required for assembly
(not included)

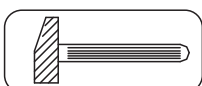

*The hardware quantities listed above are required for proper assembly.
Some extra hardware may also have been included.*

Step 1

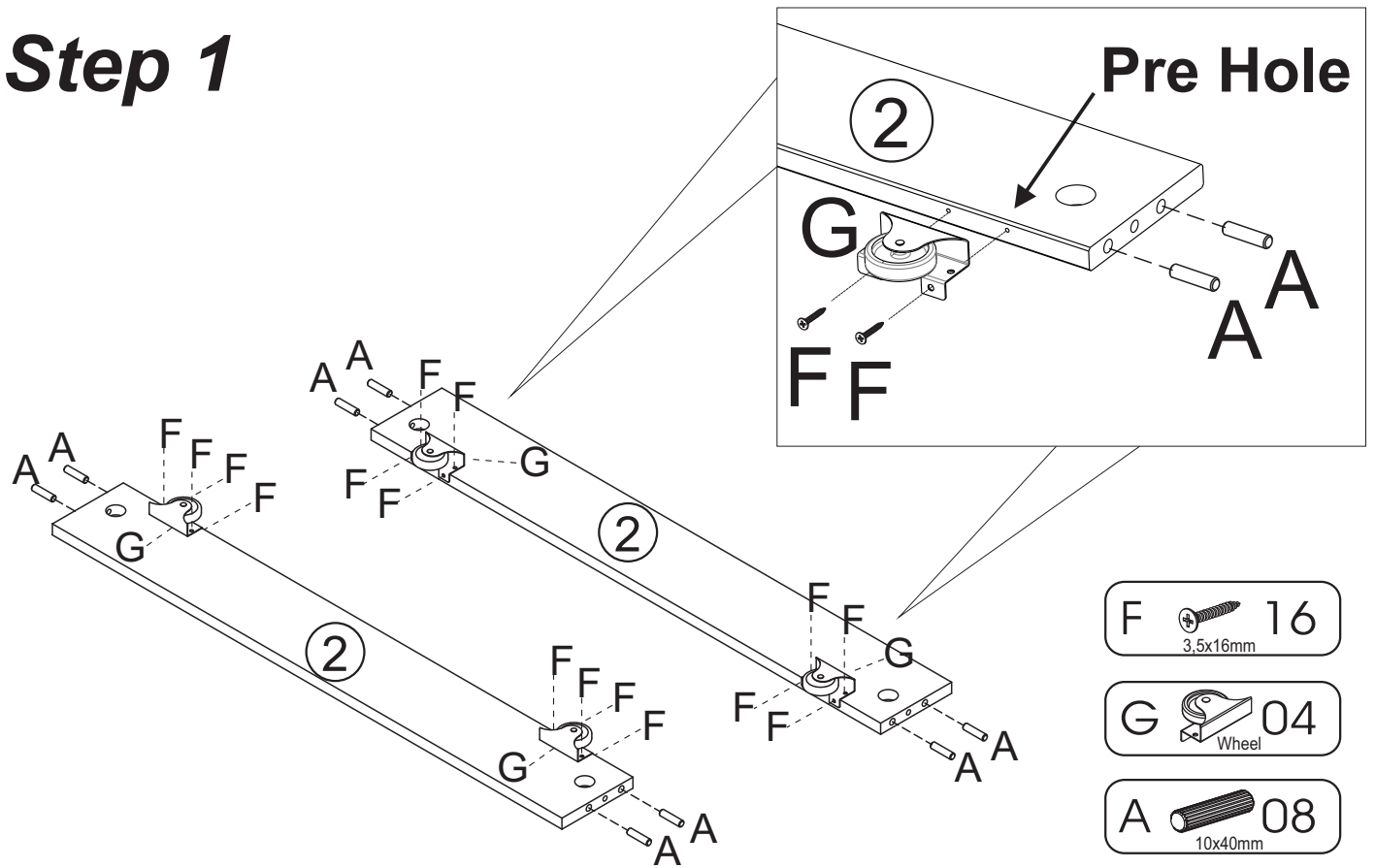

Step 2

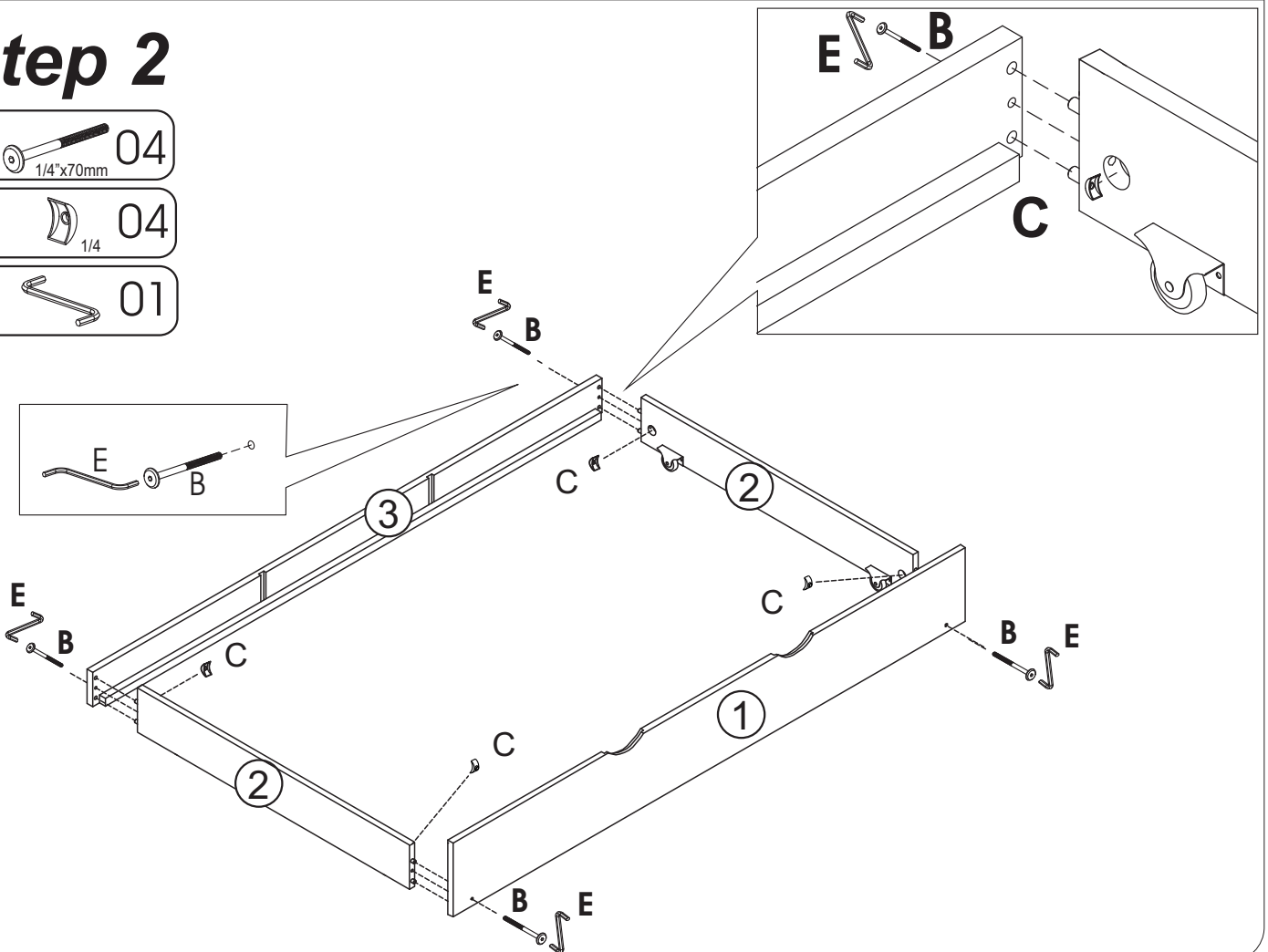
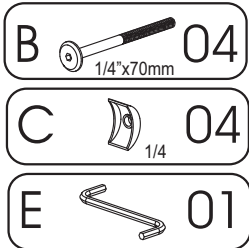

Step 3

OPTION - 1

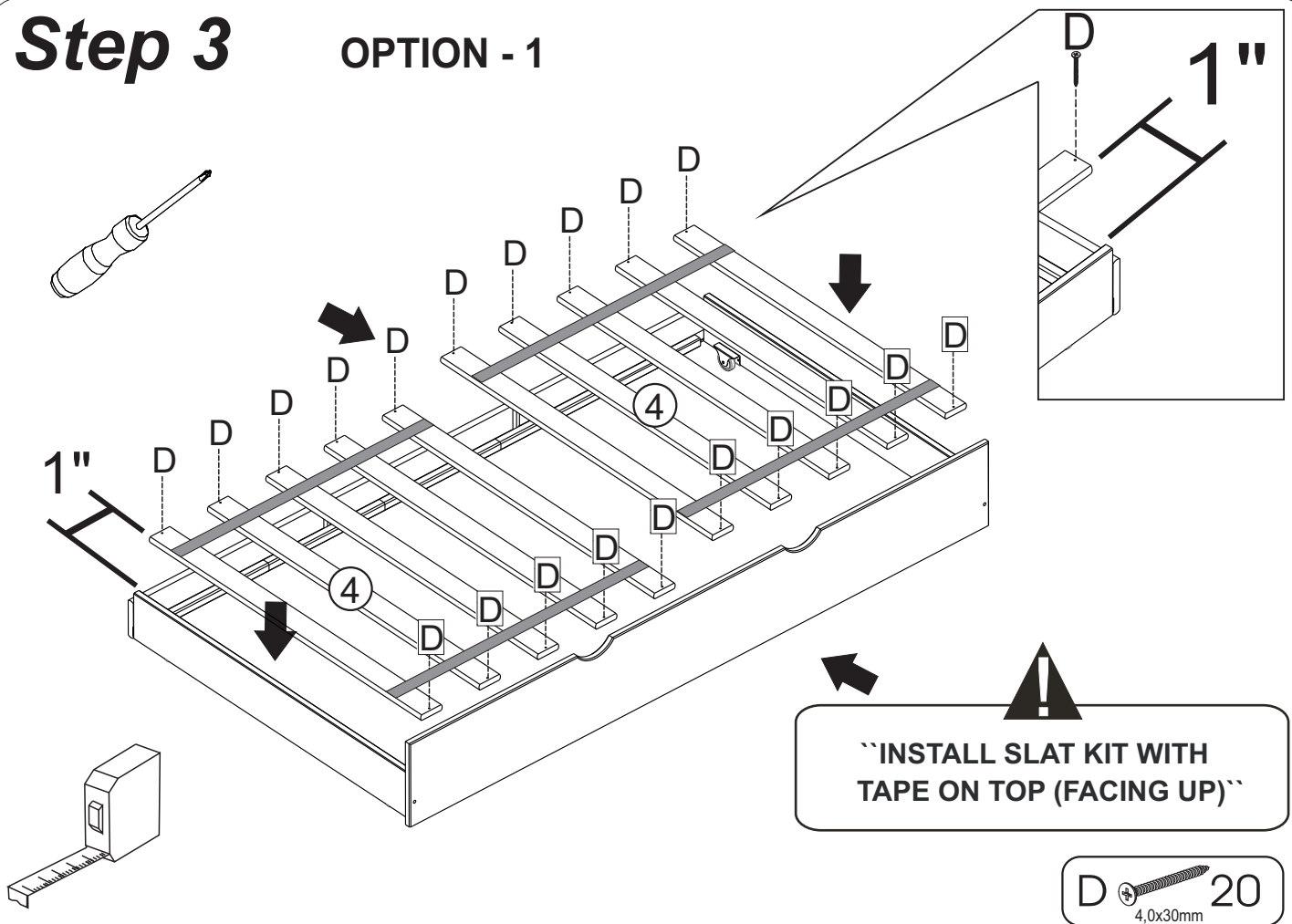

Step 4

OPTION - 2

