

# ASSEMBLY INSTRUCTION

Item: 6050-75203 Round Pedestal Dining Table

Thank you for purchasing this quality product. Be sure to unpack carefully looking for small parts which may have come loose during shipment.

Read all instruction and study the drawing carefully before starting the assembly process.

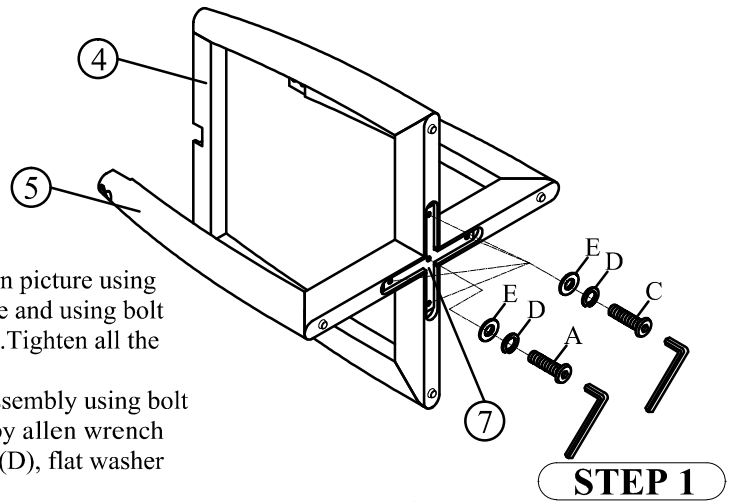

**STEP 1.** Assembly leg (4), leg (5) and metal plate (7) as shown in picture using bolt (A), lock washer (D), flat washer (E) for center hole and using bolt (C), lock washer (D), flat washer (E) for other four hole. Tighten all the bolt (A),(C), using the allen wrench (F).

**STEP 2.** Attach the stretcher (6) and metal plate (7) to the leg assembly using bolt (C), lock washer (D), flat washer (E) and tighten them by allen wrench (F). To add stretcher attach using bolt (A), lock washer (D), flat washer (E) and tighten them by allen wrench (F)

**STEP 3.** Attach the bridge (3) to the leg assembly, make sure all holes align attach using bolt (B), lock washer (D), flat washer (E) and tighten them by allen wrench (F)

**STEP 4.** turn the table halves (1) upside down on a clean soft surface attach the leg assembly to the table halves (1) as shown in the picture using bolt (B), lock washer (D), flat washer (E) and tighten them by allen wrench (F)

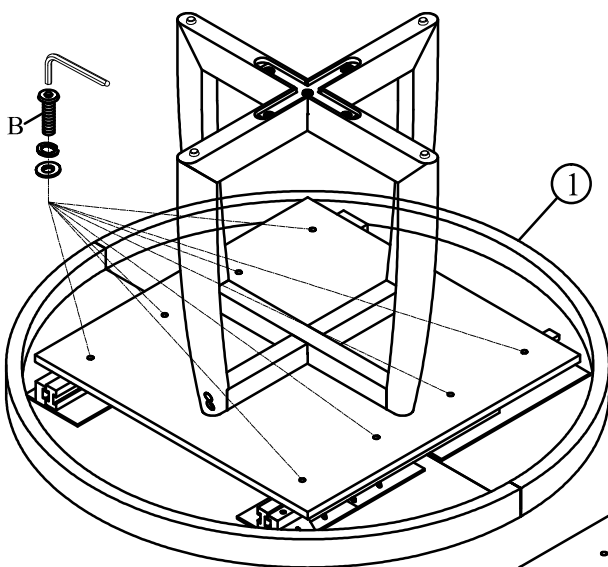

**STEP 4**

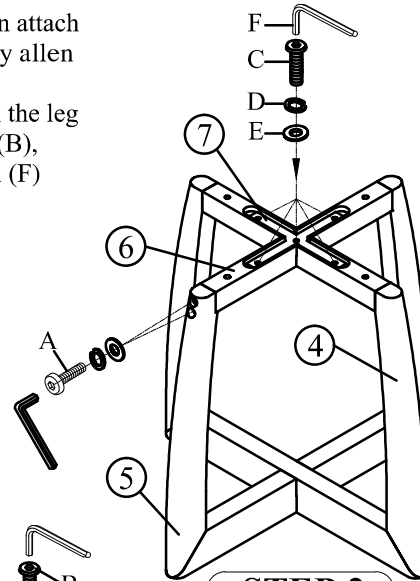

**STEP 2**

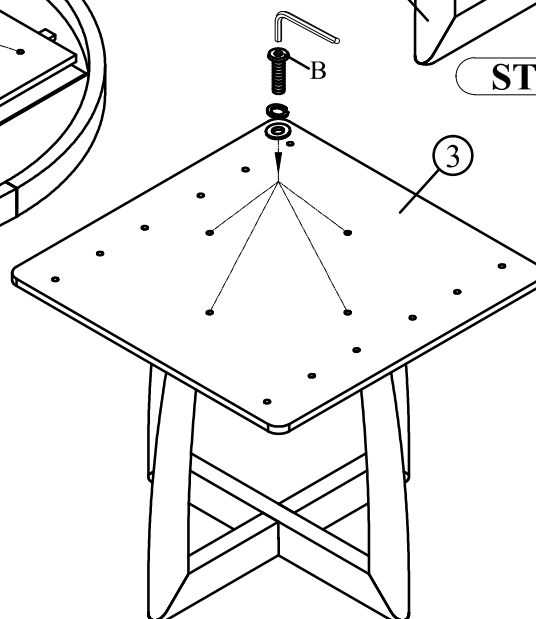

**STEP 3**

# ASSEMBLY INSTRUCTION

Item: 6050-75203 Round Pedestal Dining Table

Thank you for purchasing this quality product. Be sure to unpack carefully looking for small parts which may have come loose during shipment.

Read all instruction and study the drawing carefully before starting the assembly process.

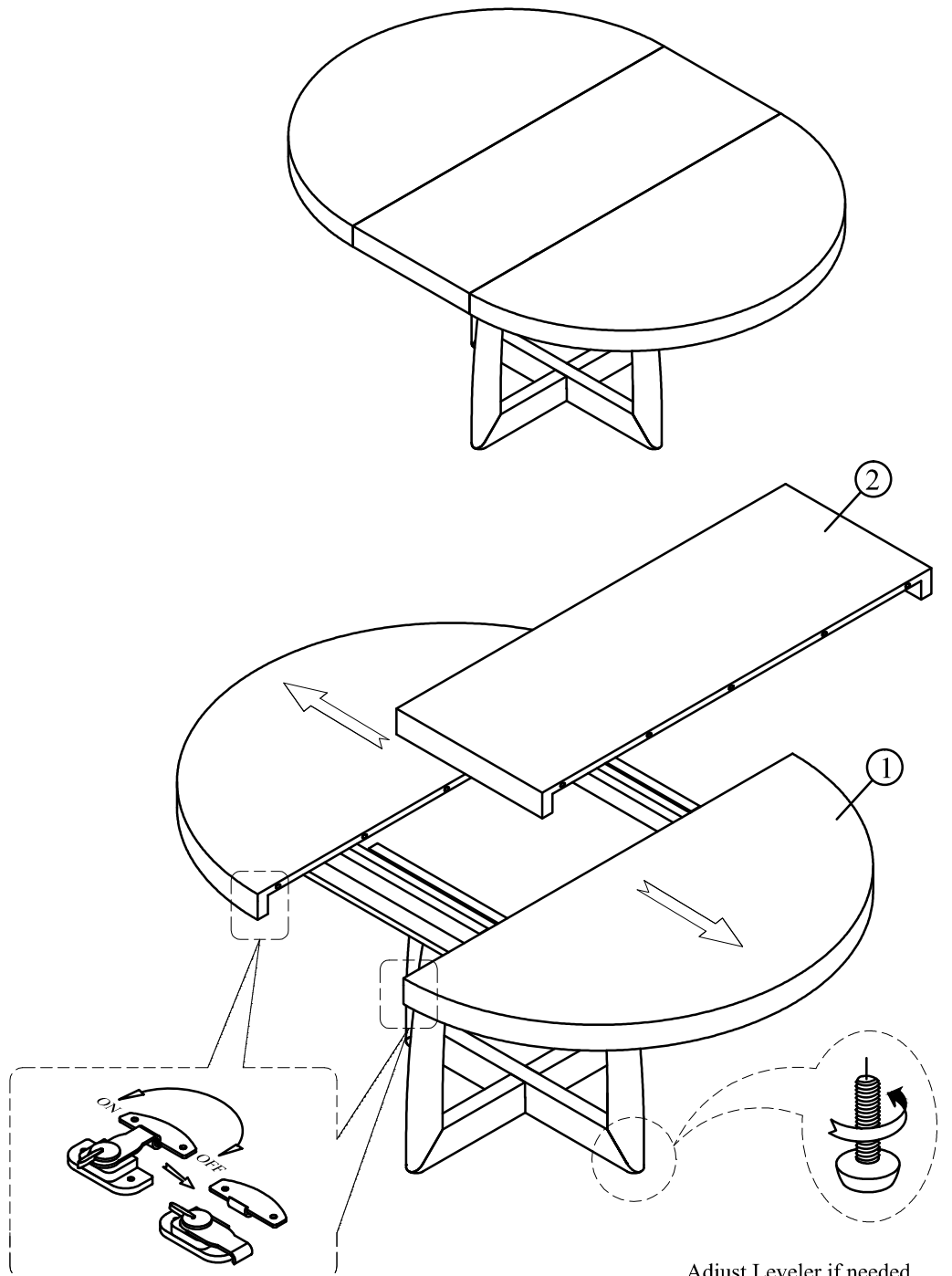



Adjust Leveler if needed  
to level table on uneven floor.



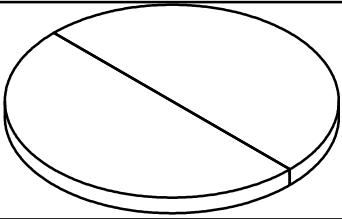
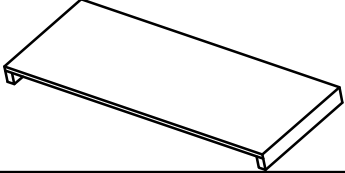
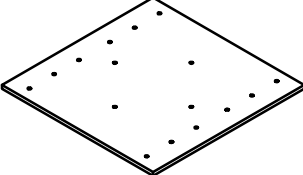
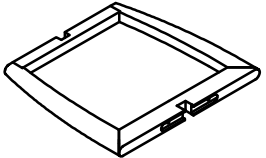
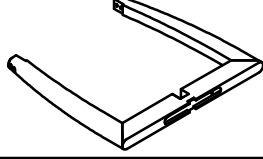
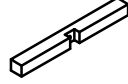

1. Open the table halves to their widest by unlocking table lock
2. Place the leaf on the table and close the table halves.

Item: 6050-75203 Round Pedestal Dining Table

PARTS LIST

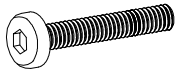
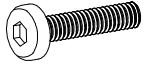
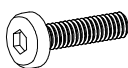
Item No	Drawing	Description	Qty
1		Table Halves	1 pc
2		Table Leaf	1 pc
3		Bridge	1 pc
4		Leg	1 pc
5		Leg	1 pc
6		Stretcher	1 pc
7		Metal plate	2 pcs

HARDWARE PACK

NO	DRAWING	DESCRIPTION	SIZE	Q'ty
A		Allen Bolt	ϕ5/16"*2-1/4"	5pcs
B		Allen Bolt	ϕ5/16"*1-3/4"	12pcs
C		Bolt	ϕ5/16"*1-1/4"	9pcs
D		Lock Washer	ϕ1/4"	26pcs
E		Flat Washer	ϕ1/4"*19D	26pcs
F		Allen Wrench	5 mm	1pc