

NOTICE

- * Please make sure that you have all parts indicated and they are in good condition before you begin assembly of this item. Refer to part list and hardware list below for guidance.
- * This item should be assembled on a soft surface to prevent scratching the finish during assembly.
- * This item may require periodic tightening.
- * If you are having difficulty, our friendly Customer Care team is always here to help. Please email customersupport@safavieh.com

PREPARATION

- * Before beginning assembly of product, make sure all parts are present. Compare parts with part contents list and hardware contents list.
- * If any part is missing or damaged, do not attempt to assemble the product.
- * Estimated Assembly Time: 10 minutes.
- * Tools Required for Assembly (included): Allen Key

MARBLE CARE

Always use felt pads under all articles to prevent discoloration. Plastic and rubber bases on items can discolor marble. Wipe up spills immediately and avoid common hazards such as hot dishes, harsh solvents, and abrasives. Cleaning should be done with a soft lint free cotton cloth dampened with water.

Part List and Hardware List

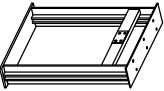
PIECE	DESCRIPTION	PICTURE	QUANTITY	CARTON CALL
A	TABLE TOP		1X	1 of 2
B	LEG FRAME		2X	2 of 2

SAFAVIEH CO U T U R E



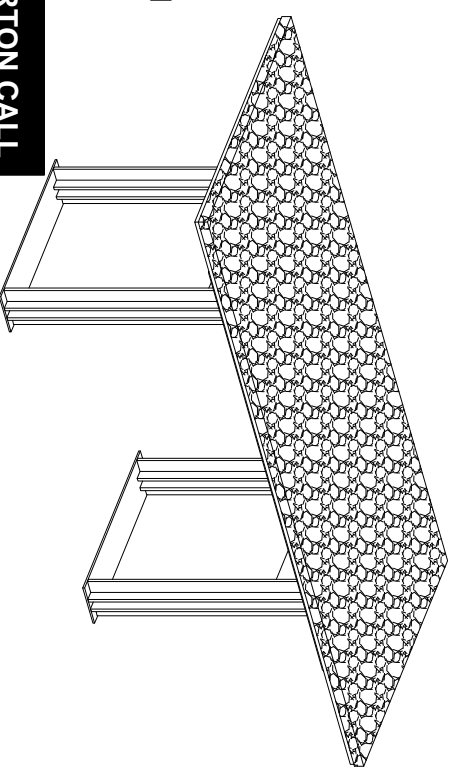

Model #: SFV7220

Product Dimensions: 78 3/4"W x 35 3/8"D x 29 1/2"H

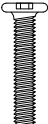

▲ WARNING ▲

Weight capacity - 200 LBS
Warning: Do not stand on Table
Warning: Do not over torque bolts

C	STRETCHER		1X	1 of 2
HW1	Bolt: M8x1.25x25 mm		20X	2 of 2
HW2	Split Lock Washer: M8		20X	2 of 2
HW3	Flat Washer: M8x20 mm		20X	2 of 2
HW4	Allen key		1X	2 of 2

PREPARATION

- * Before beginning assembly of product, make sure all parts are present. Compare parts with part contents list and hardware contents list.
- * If any part is missing or damaged, do not attempt to assemble the product.
- * Estimated Assembly Time: 10 minutes.
- * Tools Required for Assembly (included): Allen Key
- * If you are having difficulty, our friendly Customer Care team is always here to help. Please email customersupport@safavieh.com

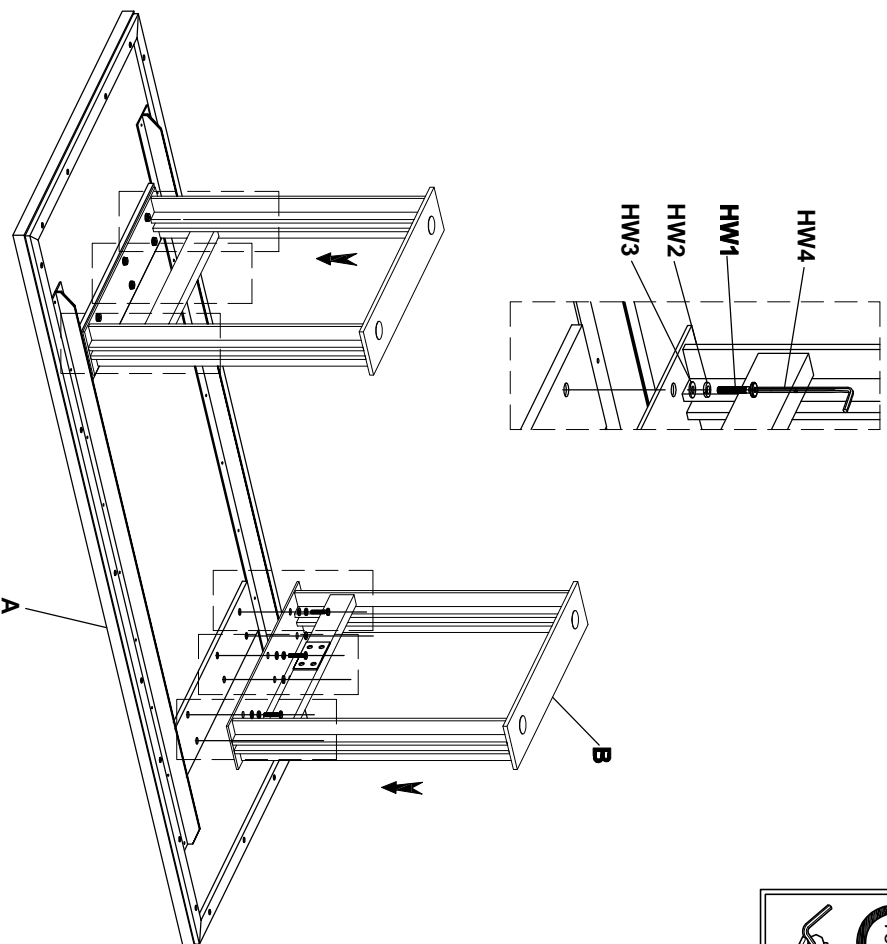

STEP1: USING A SECOND PERSON TO ASSIST YOU, PLACE THE TABLE TOP (A) UPSIDE DOWN ON A CLEAN, SCRATCH FREE SURFACE. SECURE THE TABLE TOP (A) TO THE LEG FRAME (B) BY USING THE ALLEN KEY (HW4) TO SCREW IN THE BOLTS (HW1) THROUGH THE SPLIT LOCK WASHERS (HW2) AND THEN THE FLAT WASHERS (HW3), AS SHOWN. DO NOT FULLY TIGHTEN THE BOLTS.

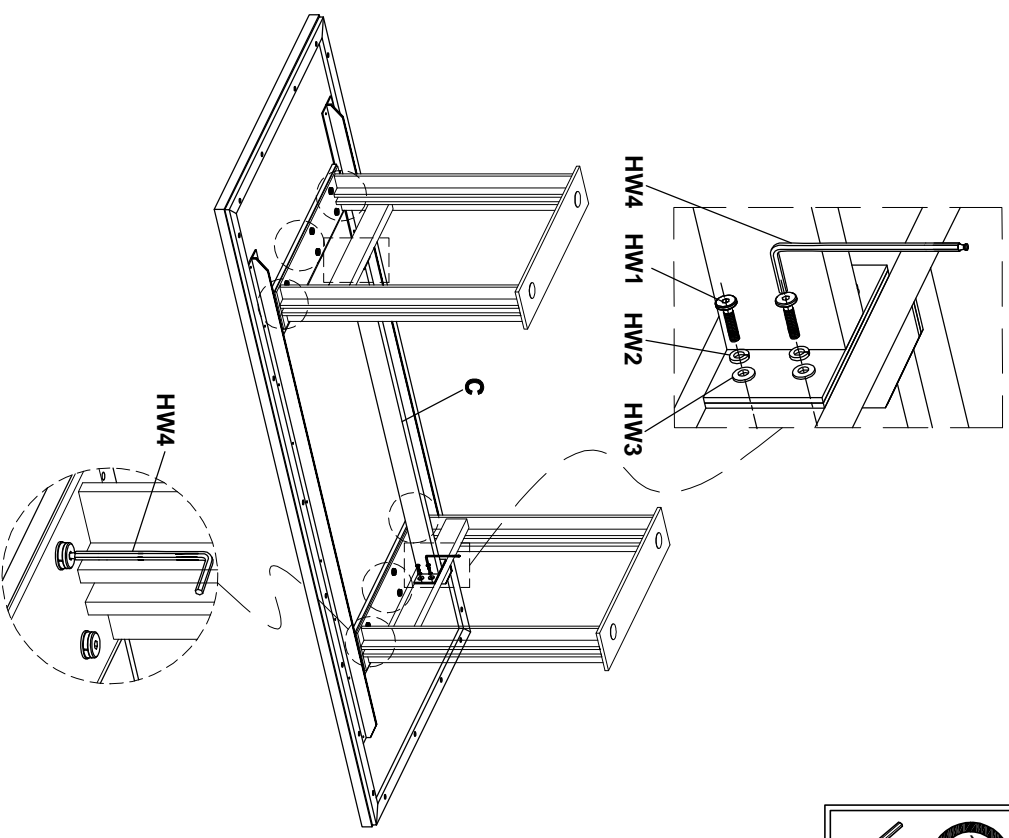

STEP2: ATTACH THE STRETCHER (C) TO THE LEG FRAME (B) BY USING THE ALLEN KEY (HW4) TO SCREW IN THE BOLTS (HW1) THROUGH THE SPLIT LOCK WASHERS (HW2) AND THEN THE FLAT WASHERS (HW3), AS SHOWN. ONCE ALL HARDWARE HAS BEEN INSTALLED, USE THE ALLEN KEY (HW4) TO FULLY TIGHTEN THE BOLTS. USING A SECOND PERSON TO ASSIST YOU, CAREFULLY TURN THE ASSEMBLED TABLE UPRIGHT.